

# 6" and 8" BARRACUDA 20 MAINTENANCE INSTRUCTIONS



Distributed by:  **MIFAB**®



# 6" and 8" BARRACUDA 20 MAINTENANCE INSTRUCTIONS

FDC

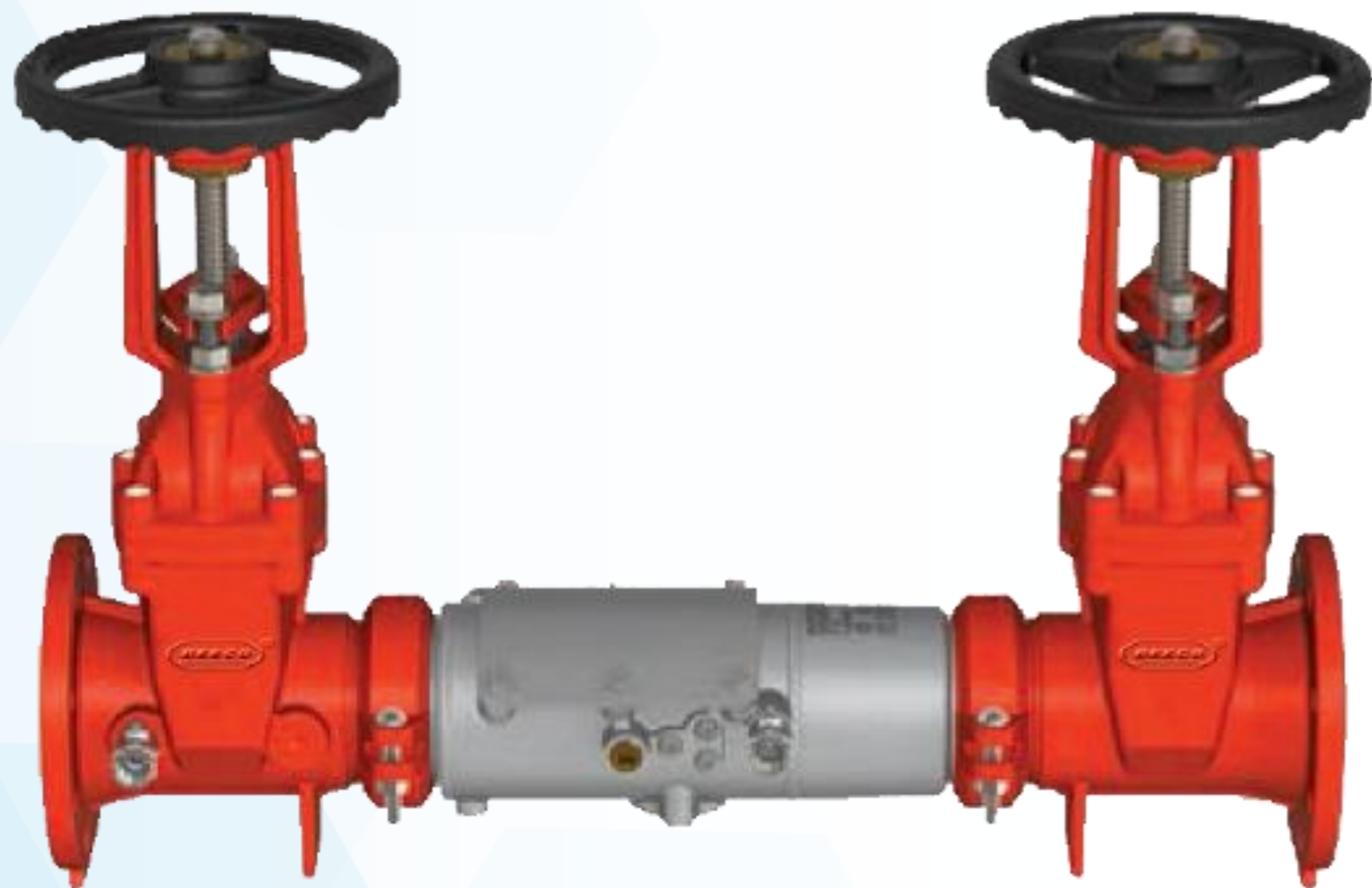

- At BEECO, we are committed to making our products as easy to install as possible. We design for most contingencies, but installation may be different based on your regional regulations or system design.
- We are continually improving our products and instructions – please help us by providing recommendations as to how we can improve our products or instructions.
- If you have any difficulties at all, please give us a call. Thank you for purchasing our product!

**READ INSTRUCTIONS IN FULL BEFORE INSTALLATION.  
QUESTIONS? CALL 773-34-3030 M-F 8:00 AM – 4:30 PM CST**

## **IMPORTANT NOTE:**

We use Stainless Steel Hardware where possible. Therefore, it is best to have Silver Anti-seize available to use on all non-wetted bolts—only a small amount is needed.

## **WARRANTY INFORMATION:**

Please visit our website for our official warranty [ww.mifab.com](http://ww.mifab.com)

**Tools Required:** This list is the recommended tools for ease of installation. Other versions of the same tool can be used. For example, Allen Wrenches instead of Allen Drive Sockets.



**#2 Philips  
Head Screwdriver**



**#2 Philips  
Head Screwdriver**



**Ratchet**



**Adjustable  
Wrench**



**BEECO Test Cock Wrench**



**Expanding  
Pipe Pliers**

**15/16" Socket  
1 1/8" Socket**



**WrenchWood Block - 2" x 4" x 5"  
Wood Block - 1" x 2" x 16"**

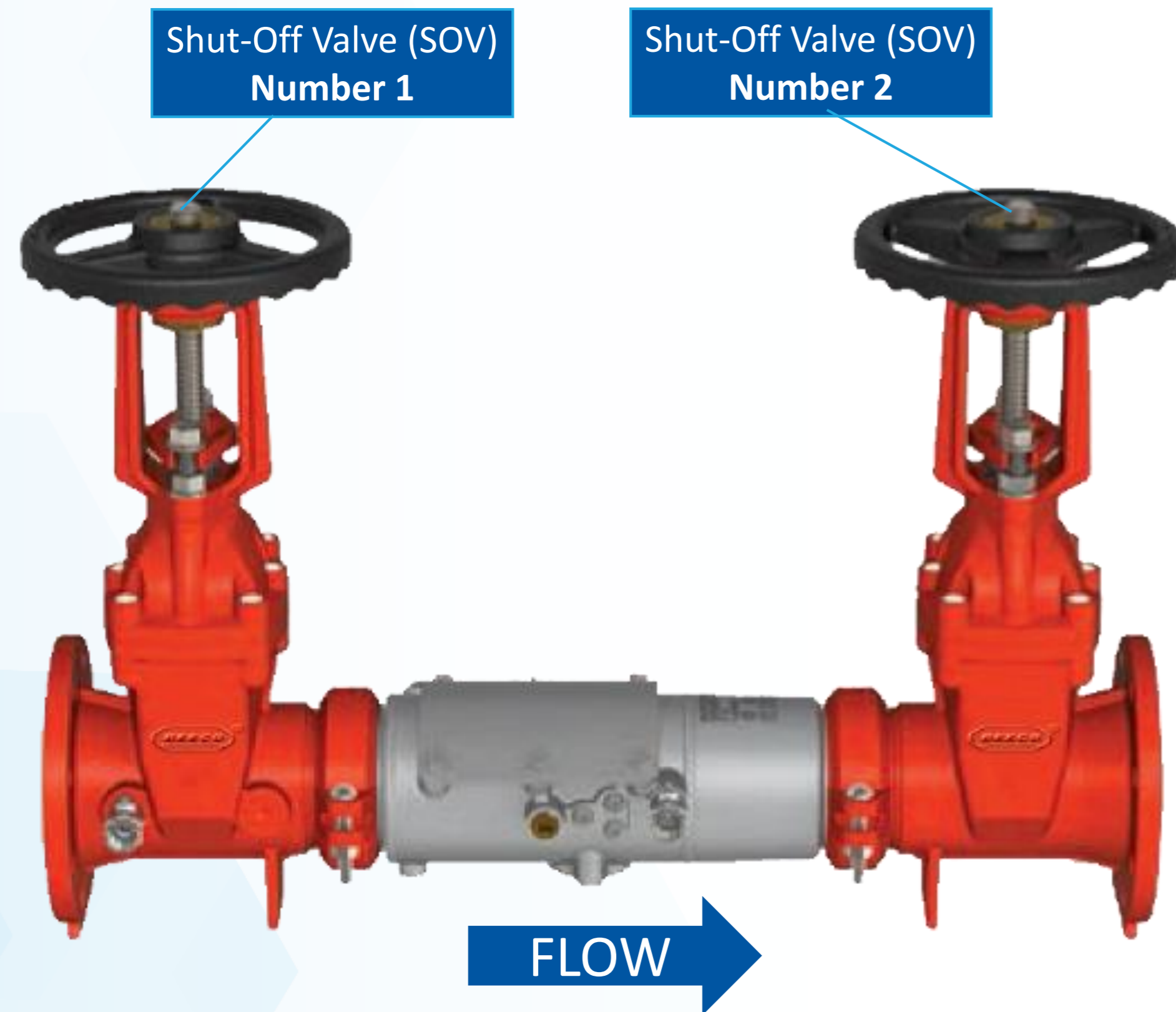

1. Slowly rotate Shut-Off Valve #2 Handle (B) clockwise to the closed position. Flag perpendicular to flow (A).
2. Slowly rotate Shut-Off Valve #1 Handle (C) clockwise to the closed position. Flag perpendicular to flow (A).

**NOTE:**

When yellow/orange position indicator flags are parallel with the flow of water the shut-off valves are in the open position. Before doing any maintenance be sure the yellow or orange flow indicators (flags) are perpendicular to the flow of water valve body indicating shut-off valves are in the closed position (A).

## Opening Test Cocks and Bleeding All Pressure from the Line Before Maintenance

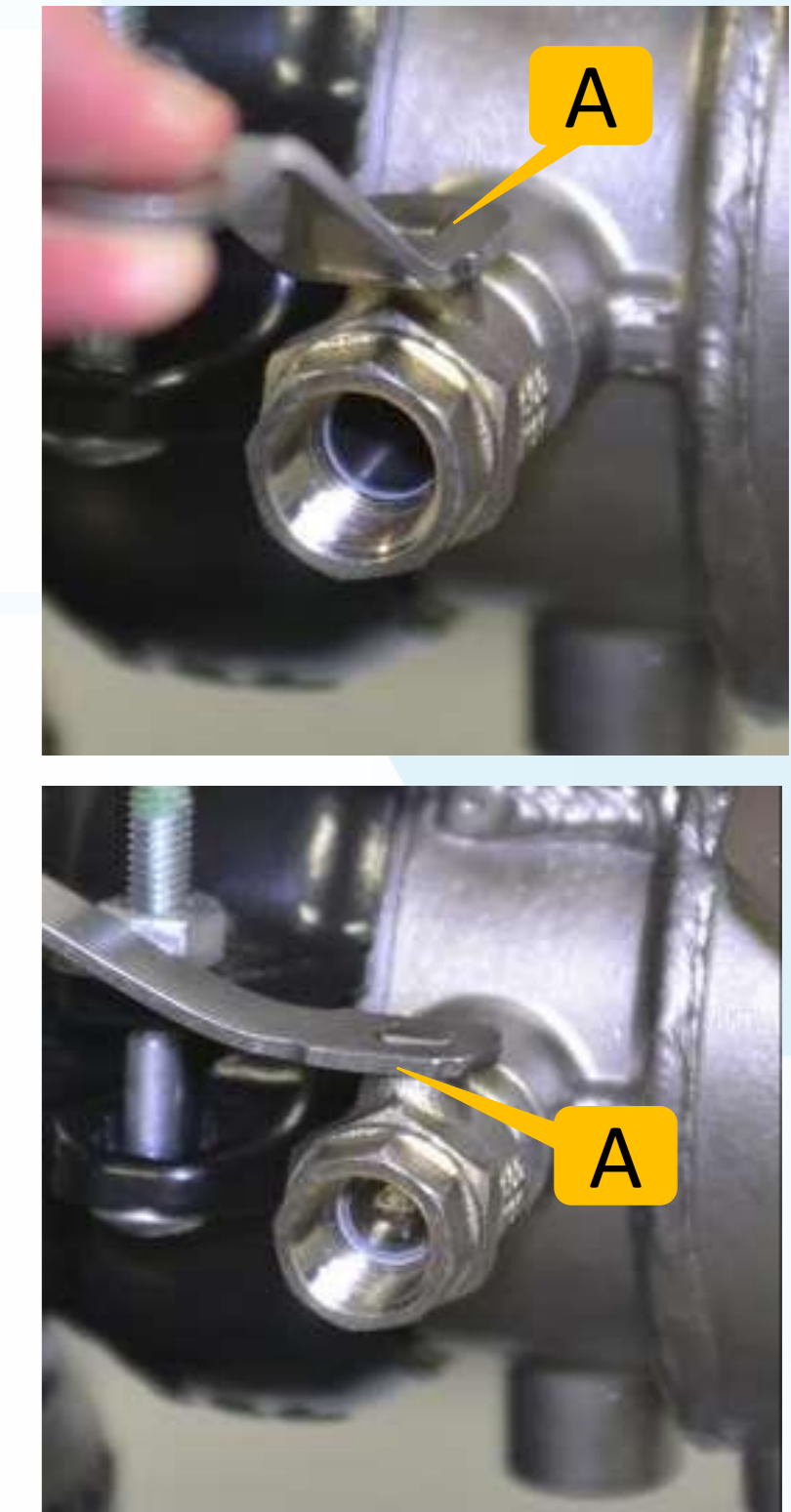
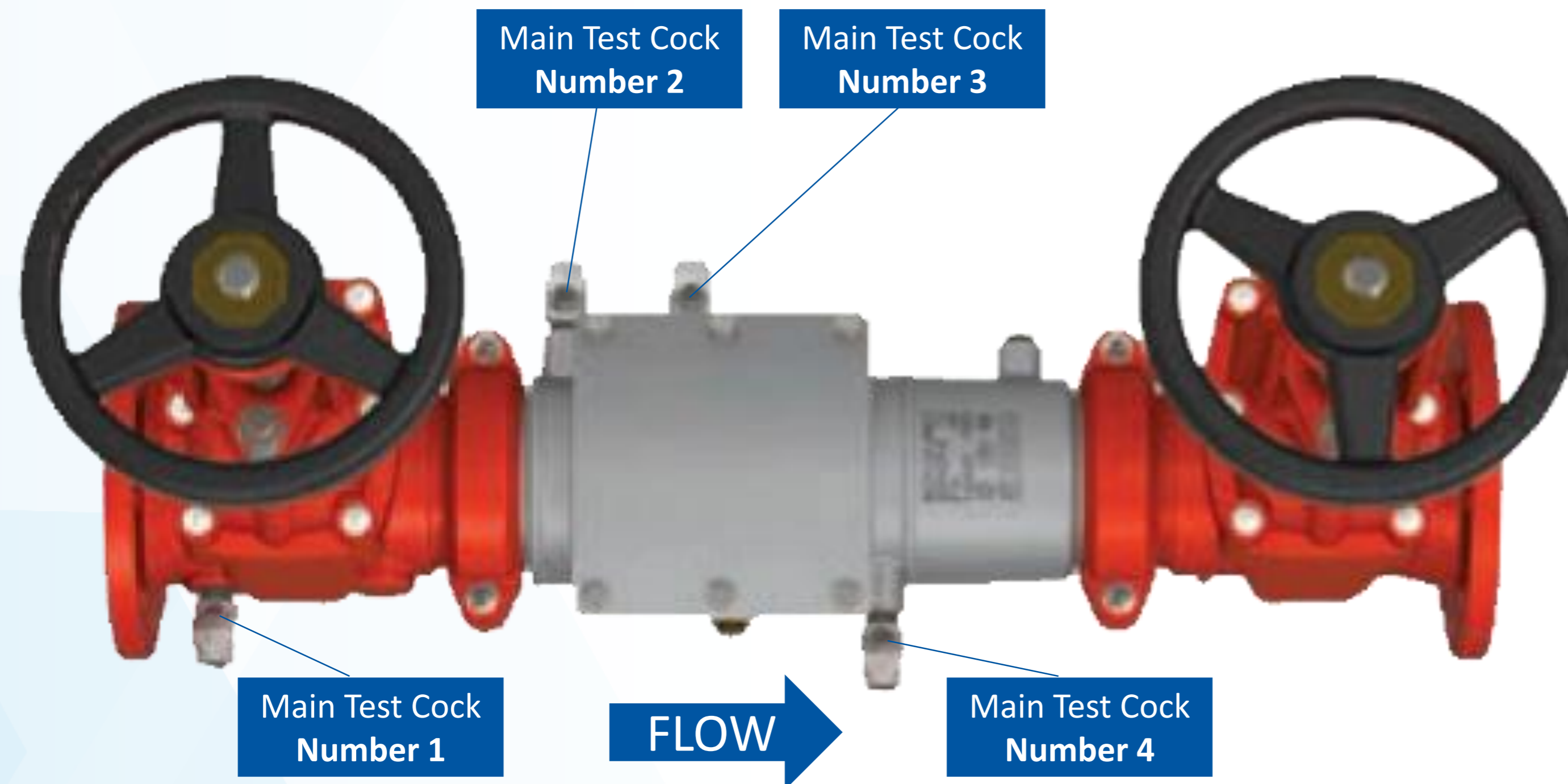

1. DO NOT OPEN Main Test Cock Number 1, as it is still subject to line pressure.
2. Using the BEECO test cock wrench or a small adjustable wrench open (A) Main Test Cock Number 4. (Test Cock is open when wrench flats are parallel to water flow through test cock).
3. Using the BEECO test cock wrench or a small adjustable wrench open Main Test Cock Number 3.
4. Using the BEECO test cock wrench or a small adjustable wrench open Main Test Cock Number 2.

## Removing Access Port Cover Plate

1. Using a 15/16" ratchet wrench loosen all six bolts on the access port cover plate (A).
2. Remove bolts and tapered washers (B) and store in a safe place. Be careful not to lose tapered washers as the access cover will not seal properly without the tapered washers.
3. Remove access port cover plate (C). Do not remove Access Port O-ring (D).

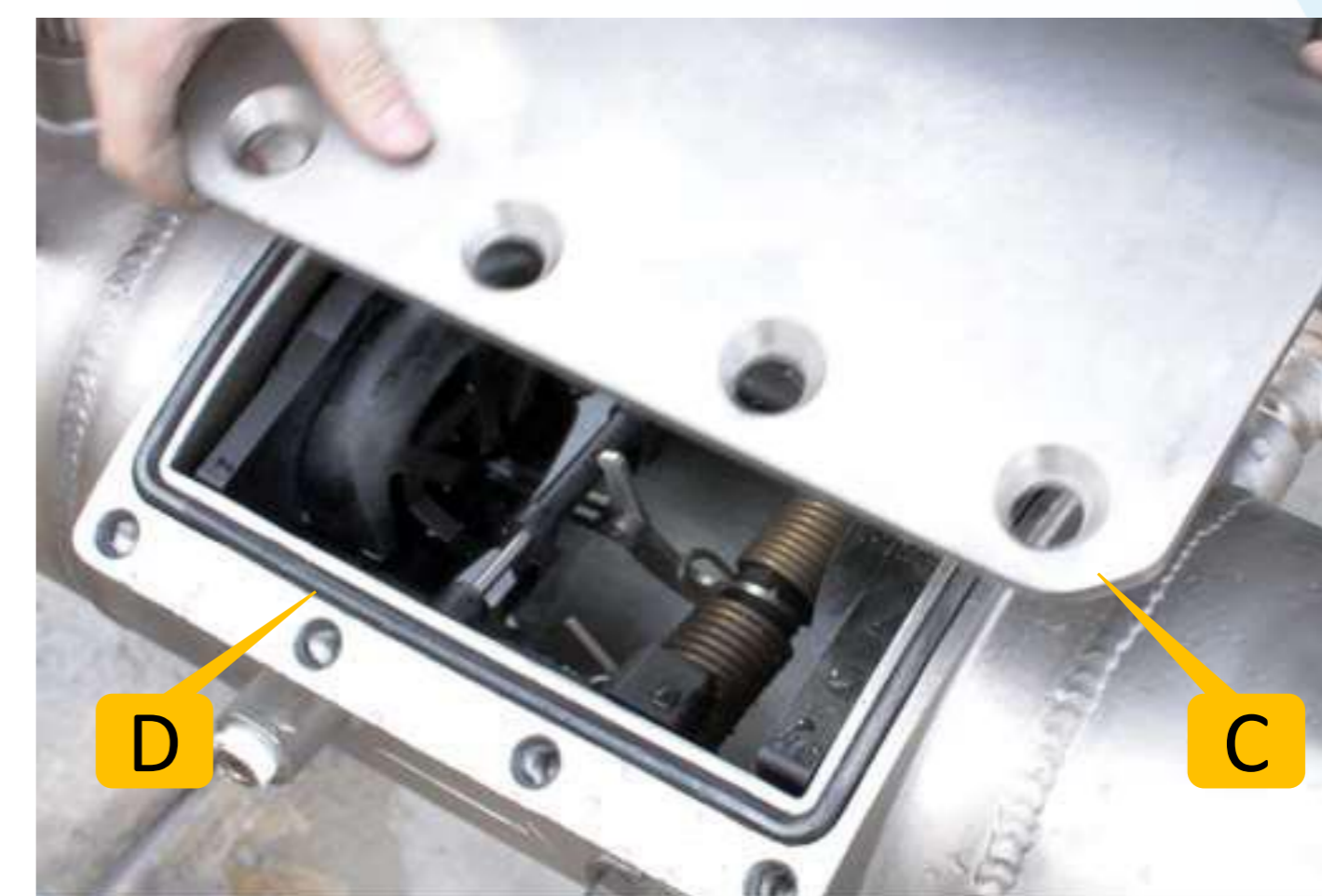

## Removing the First Dual-Action Check Module

1. Use a 15/16" Socket Wrench to loosen the check retainer bolts on both sides of the valve body (A). Do not completely remove check retainer bolts from valve body. Merely loosen the bolts until the ends of the bolts are flush with the inner wall of the valve body (B). Allow easy removal of Check Modules.
2. Insert a flathead screwdriver between the inner valve body and the First Check Module Flange (C), gently coax the First Check Module in the downstream direction until the First Check Module can easily be removed from the access port by hand.

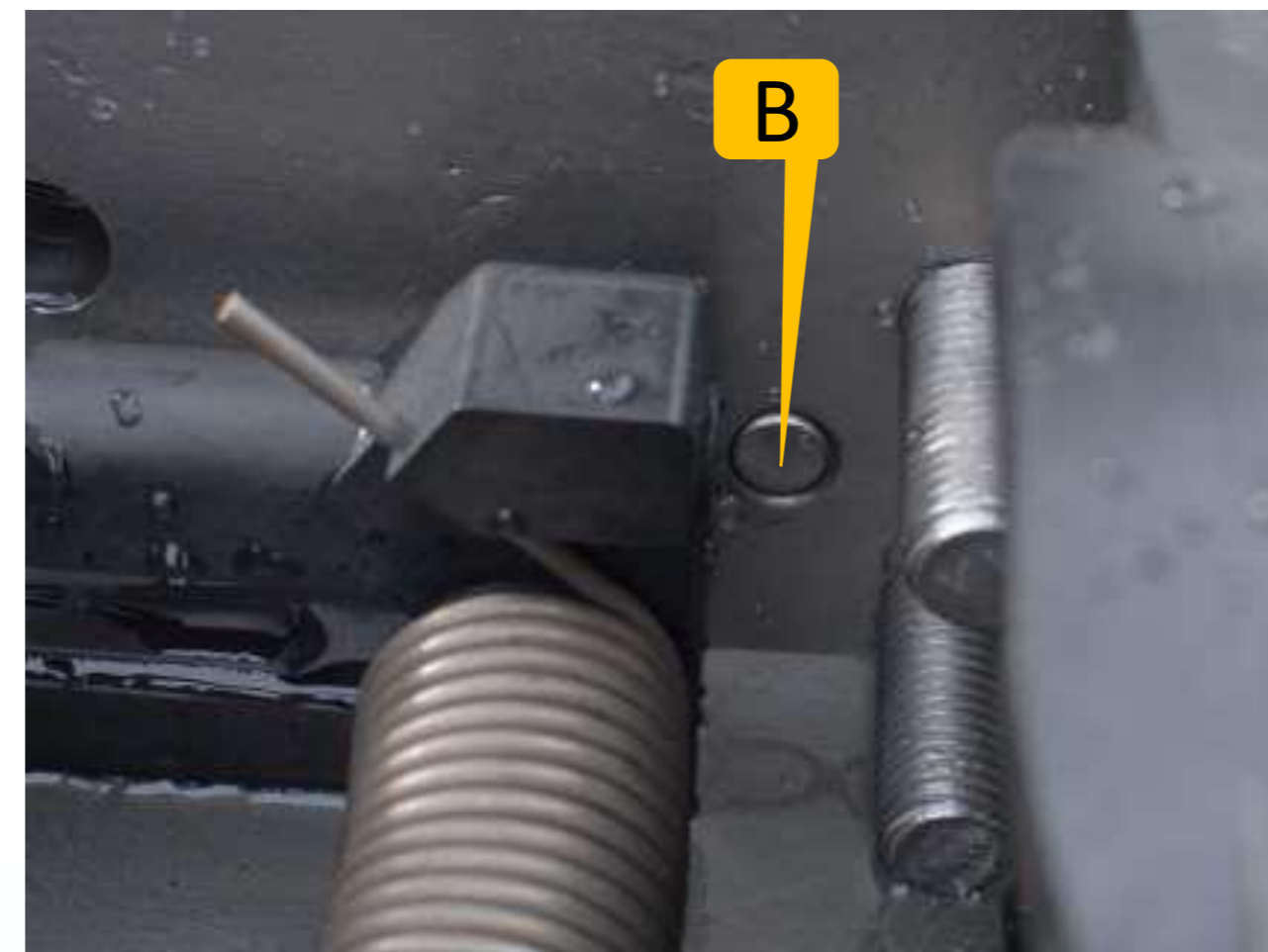
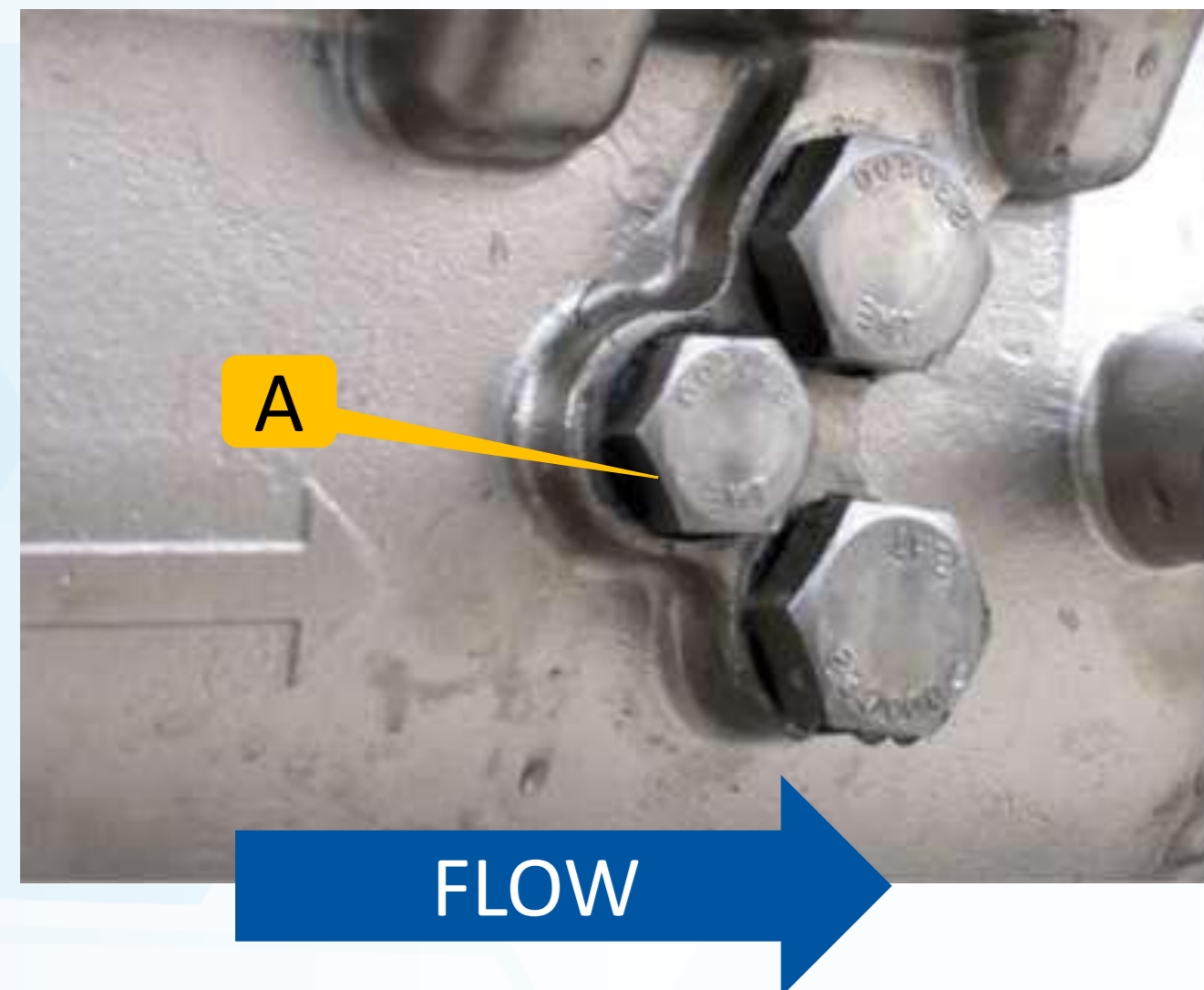

## Removing the Second Dual-Action Check Module

1. Use a 1 1/8" Socket Wrench to loosen the Check Retainer Bolts on each side of the valve body (A). Do not completely remove check retainer bolts from valve body. Merely loosen the bolts until the ends of the bolts are flush with the inner wall of the valve body(B).
2. Insert a flathead screwdriver between the inner valve body and the Second Check Module Flange (C), gently coax the Second Check Module in the upstream direction until the Second Check Module can easily be removed from the access port by hand.

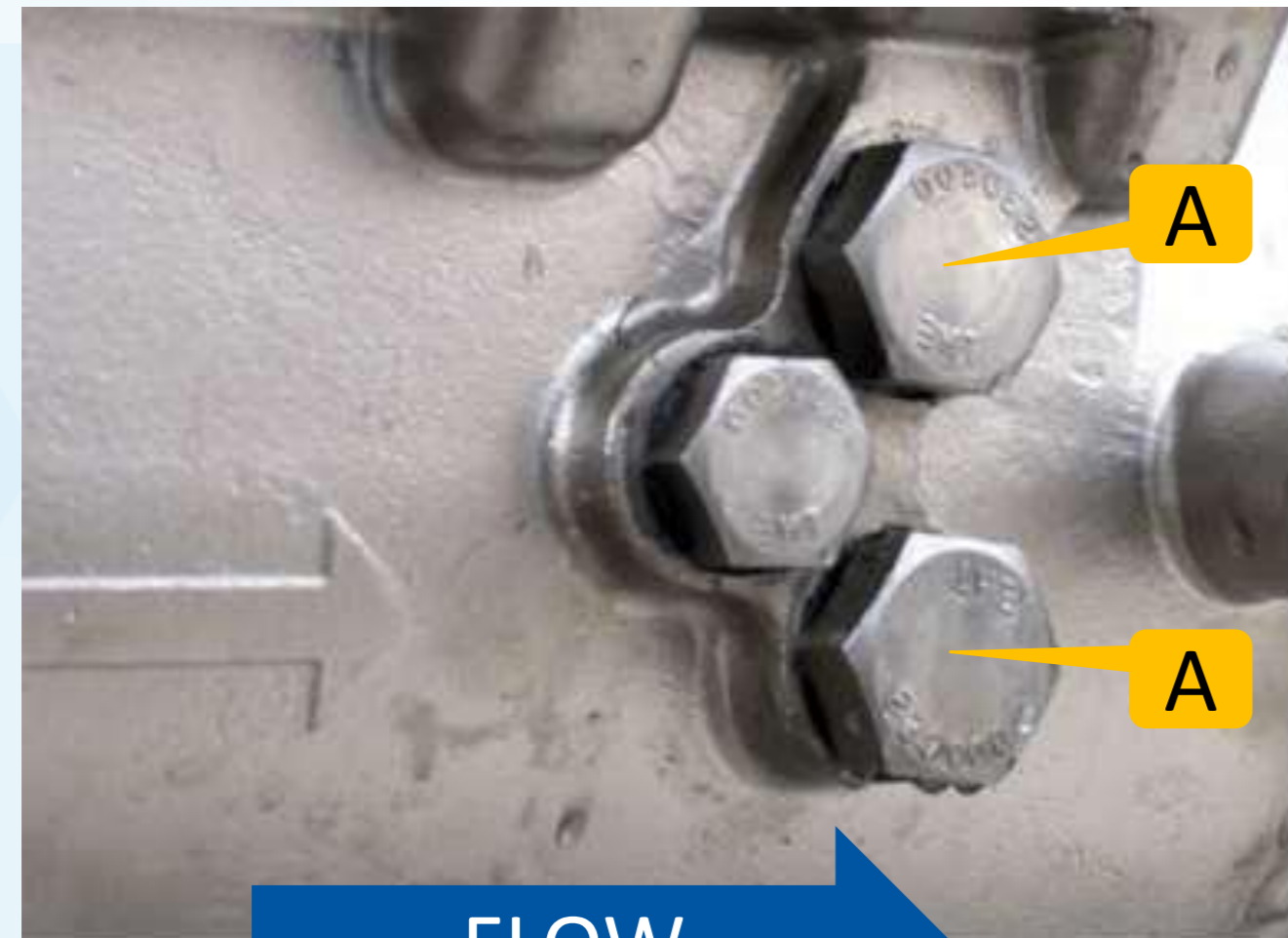

FLOW

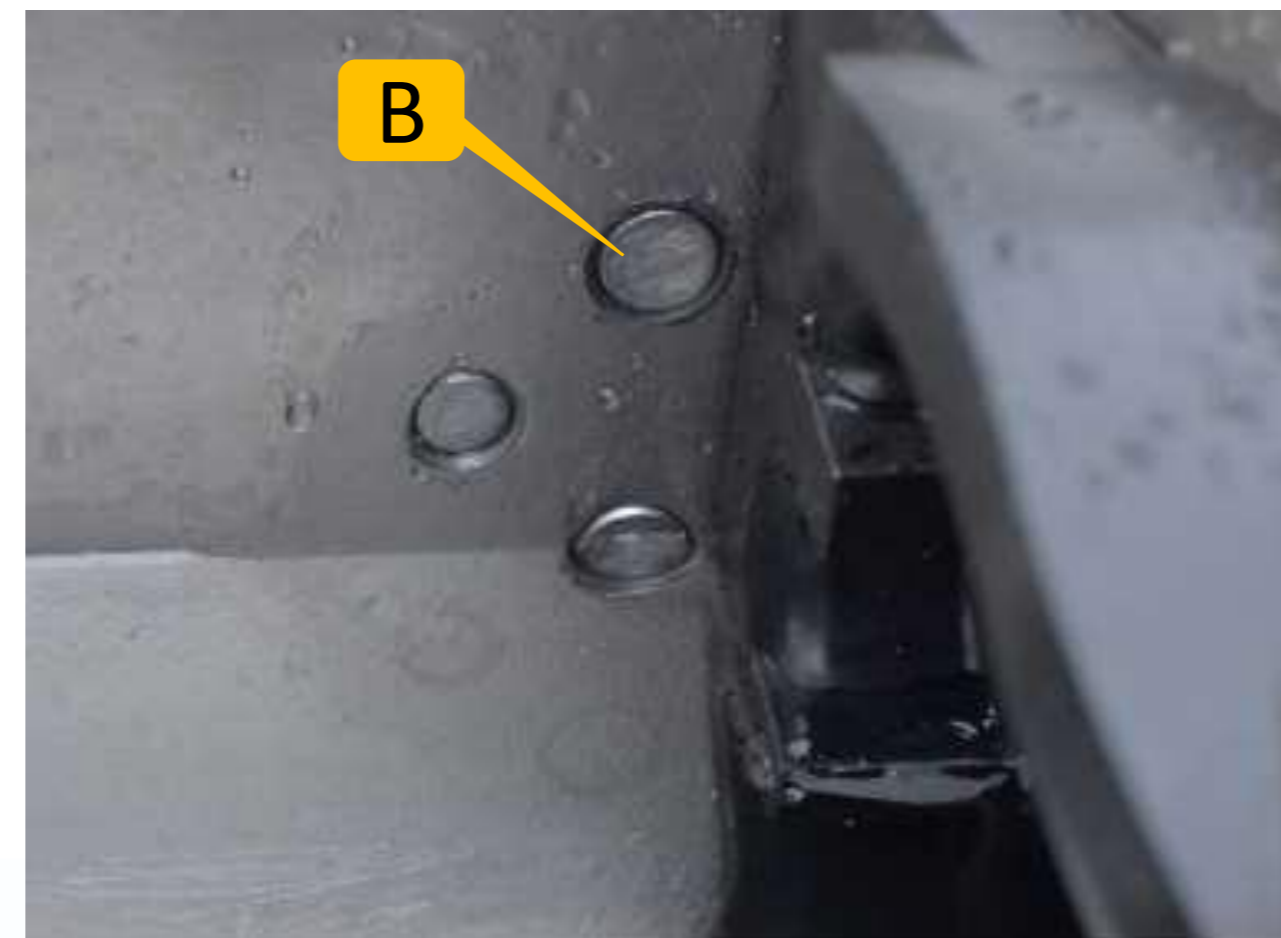



## Maintenance of First Dual-Action Check Module

1. Use a #2 Philips Head Screwdriver to remove Tower Screws (A) from the First Check Seat (B) The Double Torsion Spring is captured (C) and does not to be retained during maintenance.
2. After removing the Tower Screws (A) Examine the Elastomer Disk (D) and Check Seat (E) for fouling or damage.
3. Should Elastomer Disk (D) need replacement unscrew Disk Retainer Screws (F) and remove Disk Retainer (G). Carefully remove and replace Elastomer Disk (D). When replacing Elastomer Disk (D) be certain that no air, water or debris is trapped in the Clapper (H) cavity behind the Elastomer Disk (D).
4. Reverse the order of the above instructions to reassemble check.
  - Elastomer Disk must be flat in Clapper (H) cavity before tightening Disk Retainer Screws (F).
  - Do not cross thread Disk Retaining Screws (F).

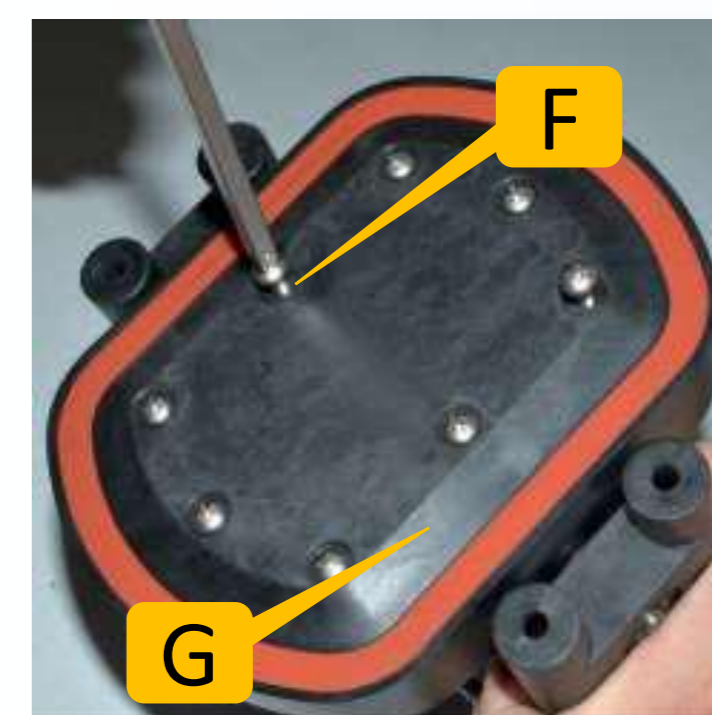
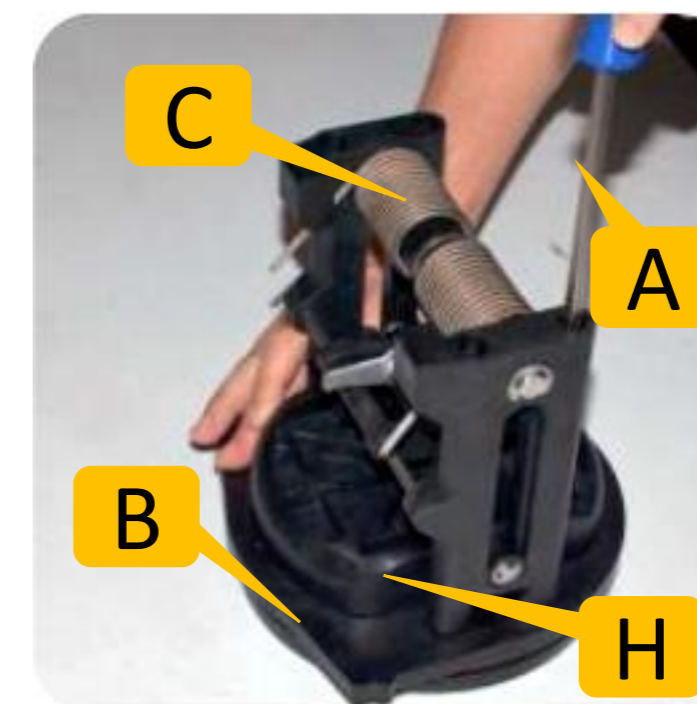

## Maintenance of First Dual-Action Check Module

**First Check Tower Bosses and Spring Arms Face Up.**

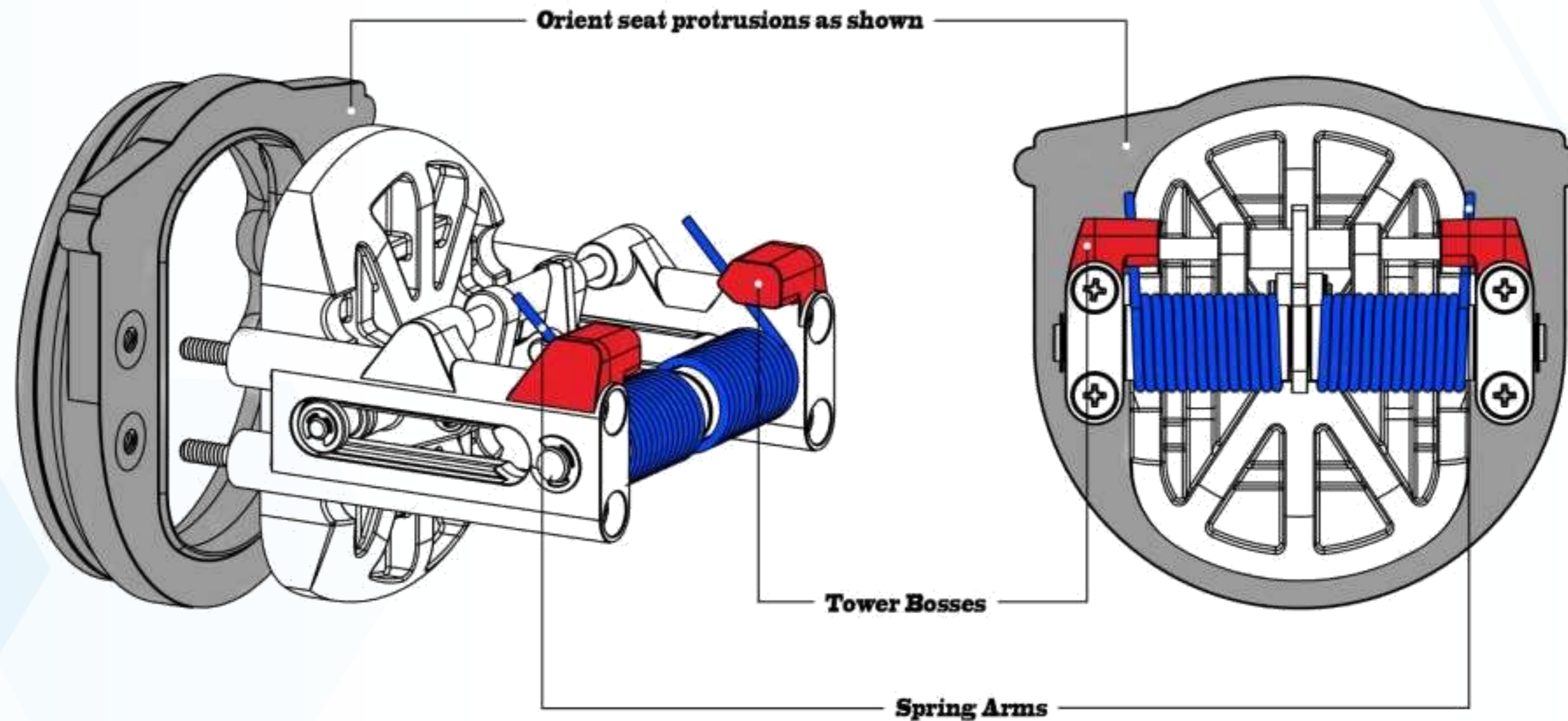

**NOTE:**

The diagram below shows the correct orientation of the First Dual-Action Check Module when being re-attached to the seat. In order to maintain the performance of the valve pay attention to the proper orientation of the check module.

## Maintenance of Second Dual-Action Check Module

1. Use a #2 Philips Head Screwdriver to remove Tower Screws (A) from the Second Check Seat (B) The Double Torsion Spring is captured (C) and does not to be retained during maintenance.
2. After removing the Tower Screws (A) Examine the Elastomer Disk (D) and Check Seat (E) for fouling or damage.
3. Should Elastomer Disk (D) need replacement unscrew Disk Retainer Screws (F) and remove Disk Retainer (G). Carefully remove and replace Elastomer Disk (D). When replacing Elastomer Disk (D) be certain that no air, water or debris is trapped in the Clapper (H) cavity behind the Elastomer Disk (D).
4. Reverse the order of the above instructions to reassemble check.
  - Elastomer Disk must be flat in Clapper (H) cavity before tightening Disk Retainer Screws (F).
  - Do not cross thread Disk Retaining Screws (F).

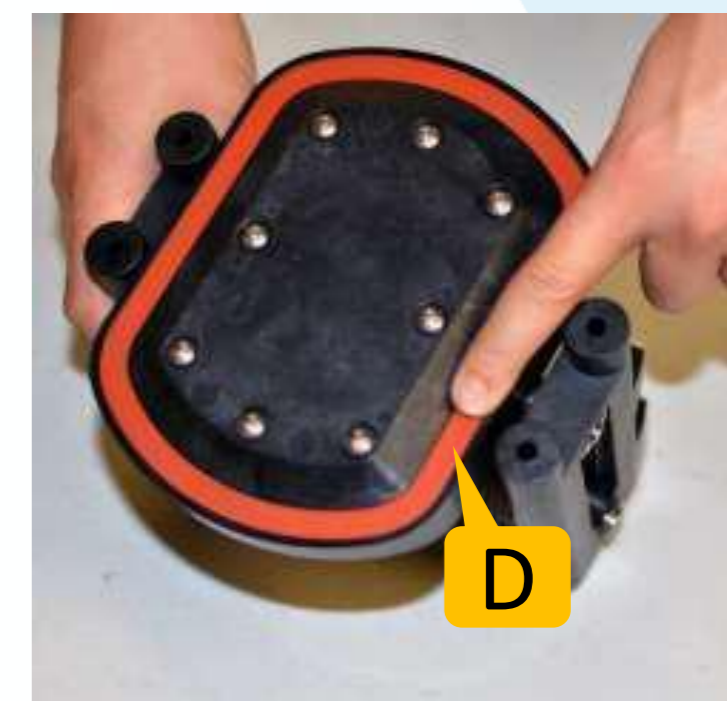
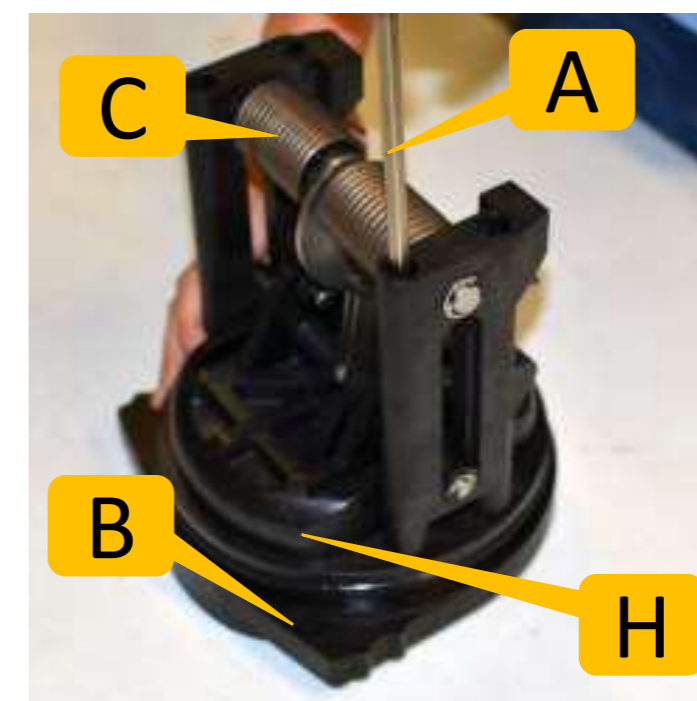
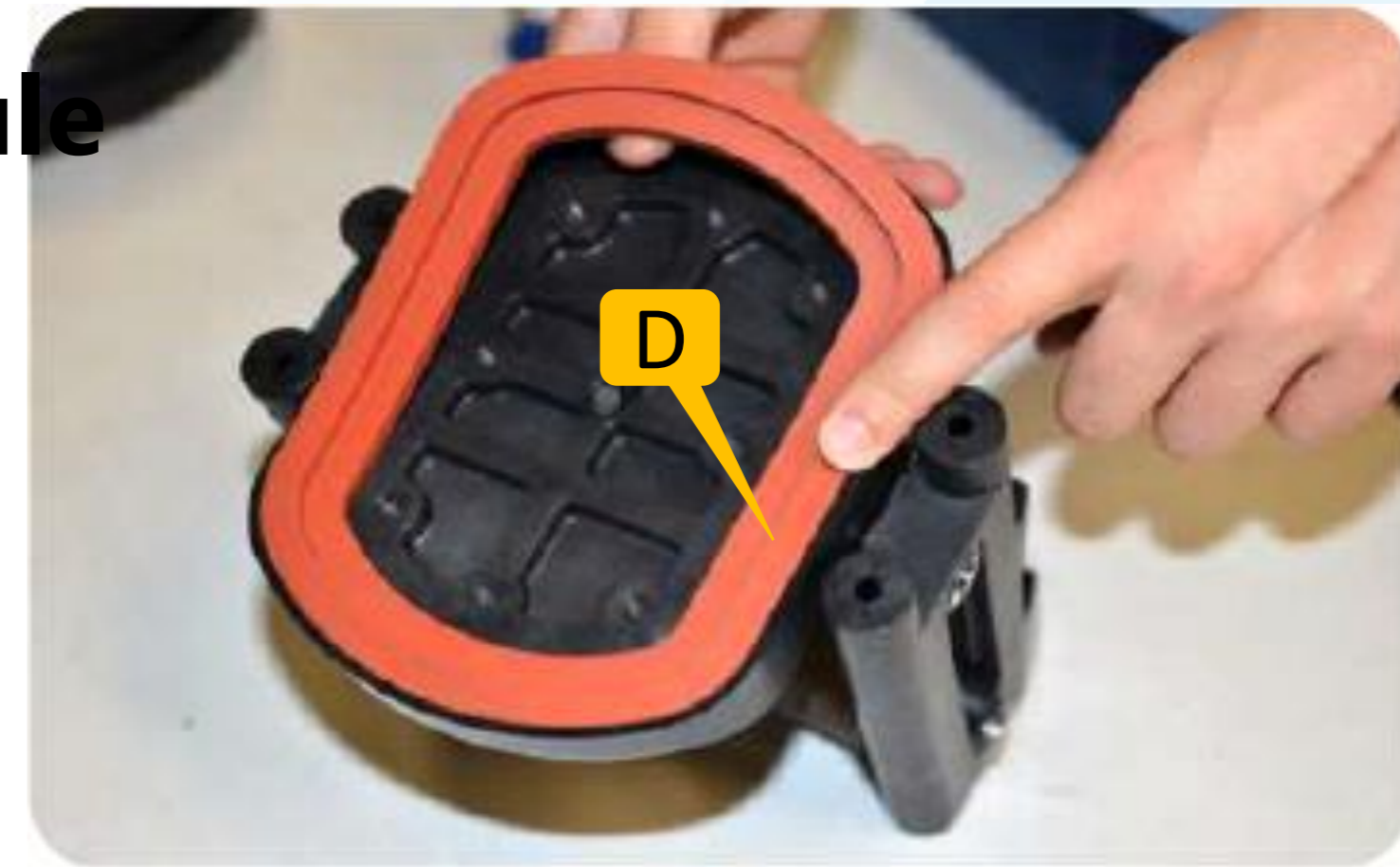

## Maintenance of Second Dual-Action Check Module

**Second Check Tower Bosses and Spring Arms Face Down.**

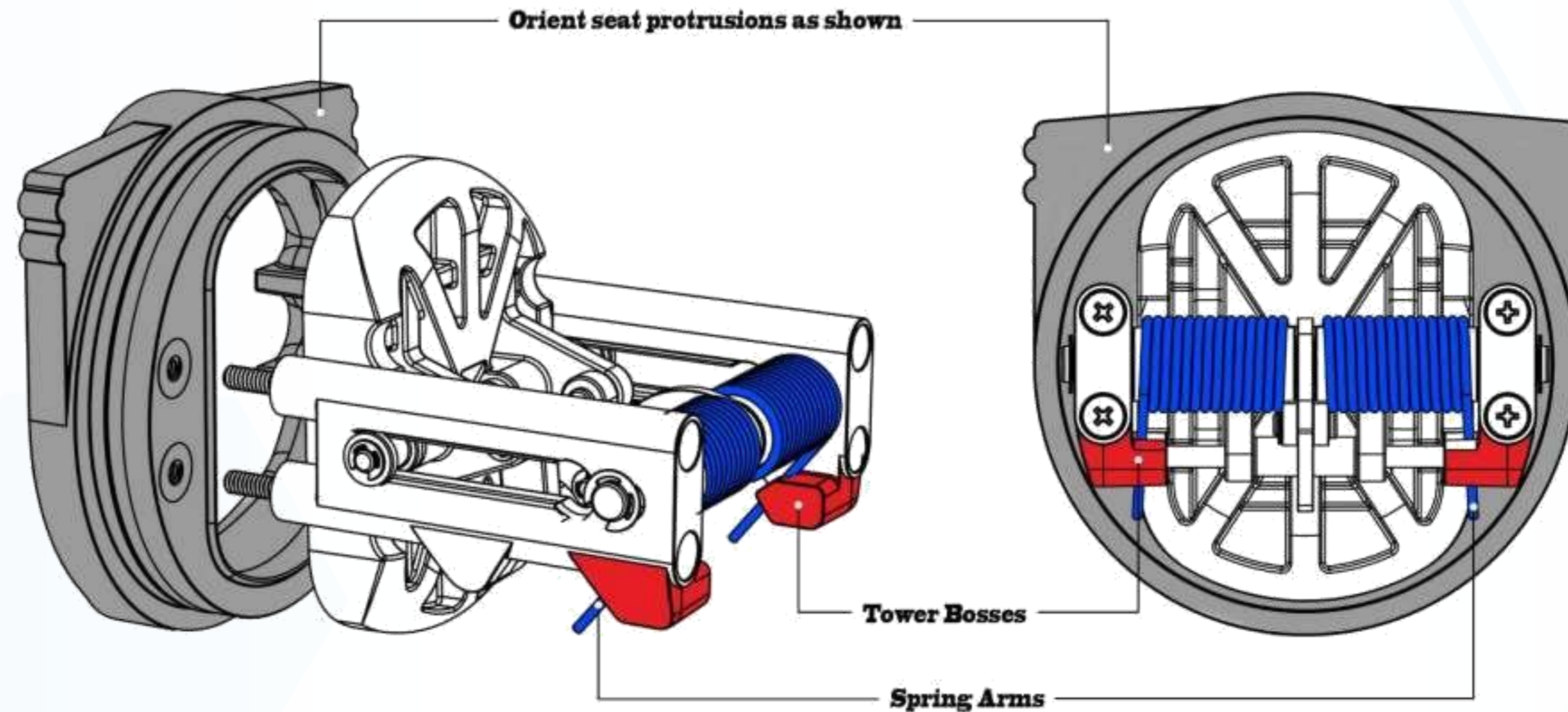

### **NOTE:**

The diagram below shows the correct orientation of the Second Dual-Action Check Module when being re-attached to the seat. In order to maintain the performance of the valve pay attention to the proper orientation of the check module.

## Installing Second Dual Action Check Module

1. Insert Second Check Module (A) into Access Port (B) with Second Check Towers (C) pointing downstream. Push Second Check Module (A) downstream into Valve Sealing Ring (D) until Check O-ring (E) rests against Valve Sealing Ring (D). Coax Second Check Module (A) into its fully seated position by hand.
2. Alternatively place 2"x4" piece of wood cut to 5" length (F) against the backside of the Second Check Seat Ring (G). Using a 1"x4" piece of wood cut to 16" length (H) as a lever between Access Port Wall the 2"x4" (F) gently coax the Second Check Module (A) into its fully seated position.
3. Be certain Second Check Module (A) is fully seated and Check O-ring (E) is NOT "fish mouthed" or damaged.
4. Tighten the Second Check Retaining Screws (I) ONLY AFTER the First Check Module (A) has been installed.

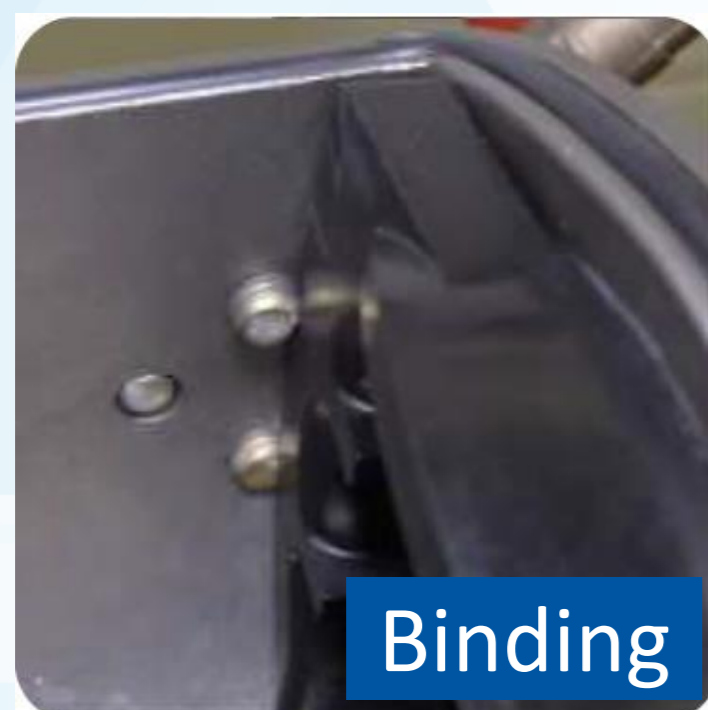
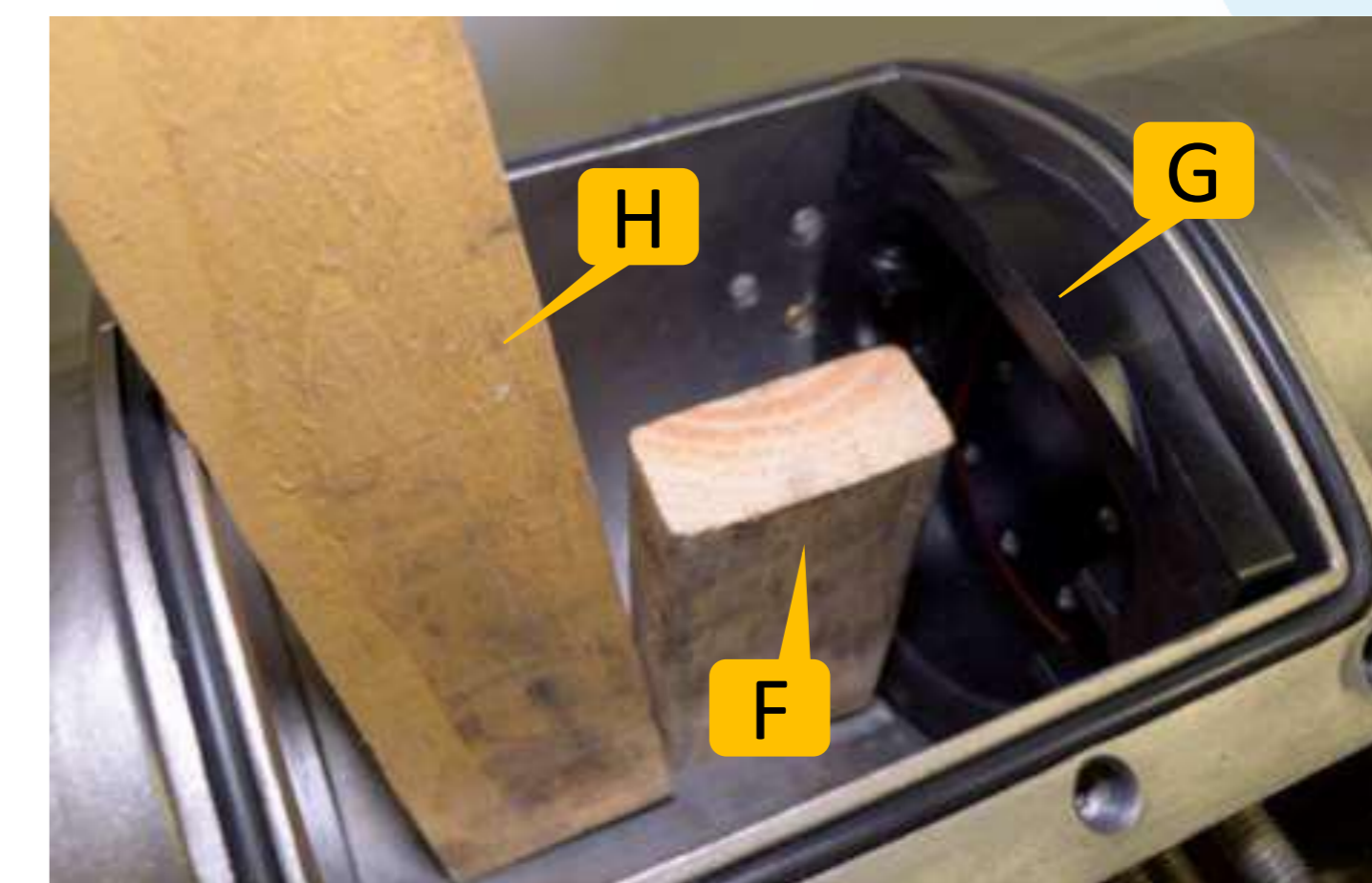
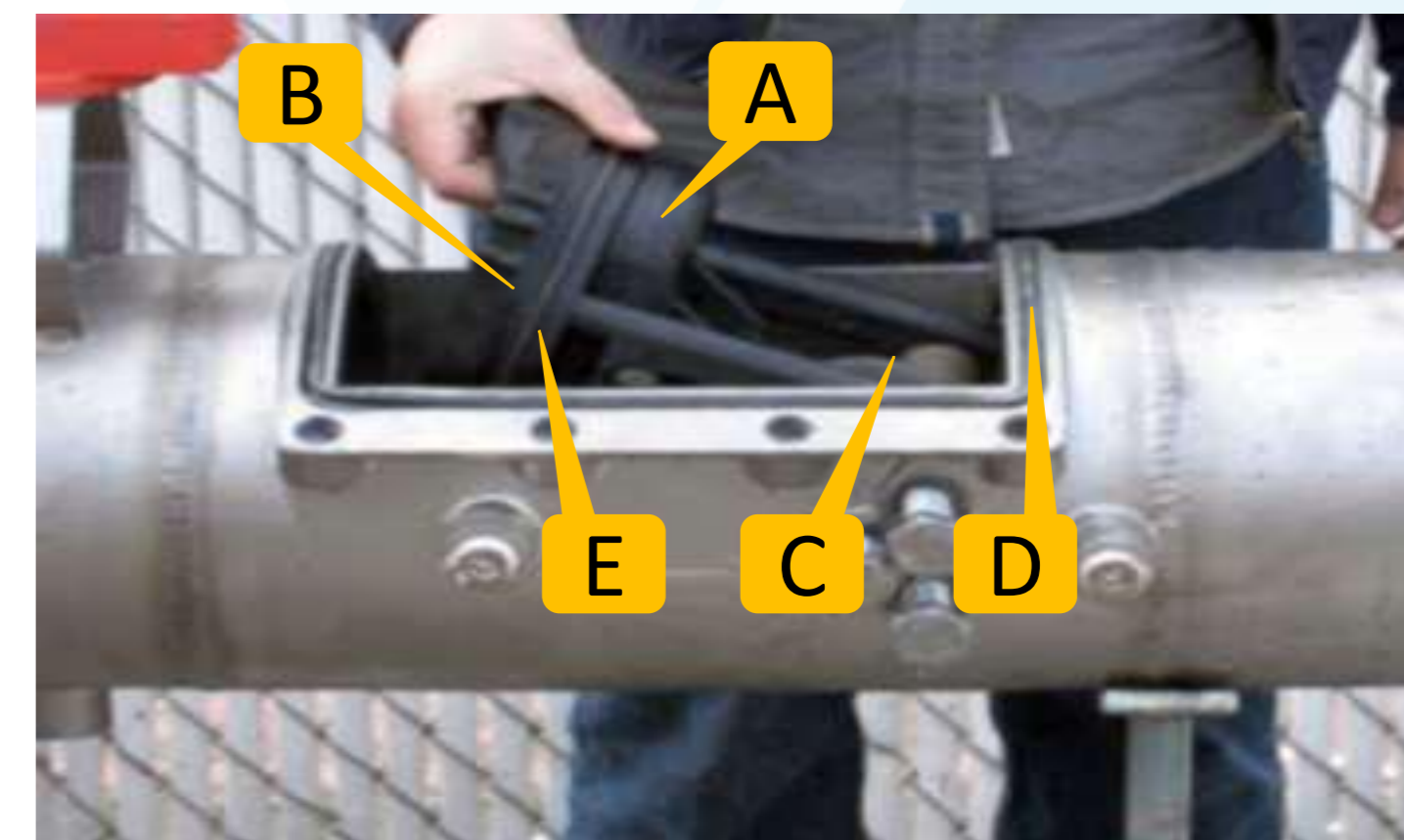

### WARNING:

The Second Check Module must be fully seated to insure Retainer Screws do not bind against Check Seat. Binding Retainer Screws against Check Seat will result in permanent damage to Second Check Modules.

## Installing First Dual-Action Check Module

1. Insert First Check Module (A) into Access Port (B) with First Check Towers (C) pointing downstream. Push First Check Module (A) upstream into Valve Sealing Ring (D) until Check O-ring (E) is resting against Valve Sealing Ring (D). Coax First Check Module (A) into its fully seated position by hand.
2. Alternatively, using a piece of 1"x4" wood cut to 16" length (F) as a lever between the Second Check Seat (G) and the First Check Towers (C), coax the First Check Module (A) into its fully seated position.
3. Be certain First Check Module (A) is fully seated and Check O-ring (E) is NOT "fish mouthed" or damaged.
4. Now fully tighten the First and Second Check Retaining Screws (I).

### WARNING:

The First Check Module must be fully seated to insure Retainer Screws do not bind against Check Towers. Binding Retainer Screws against Check Towers will result in permanent damage to First Check Modules.

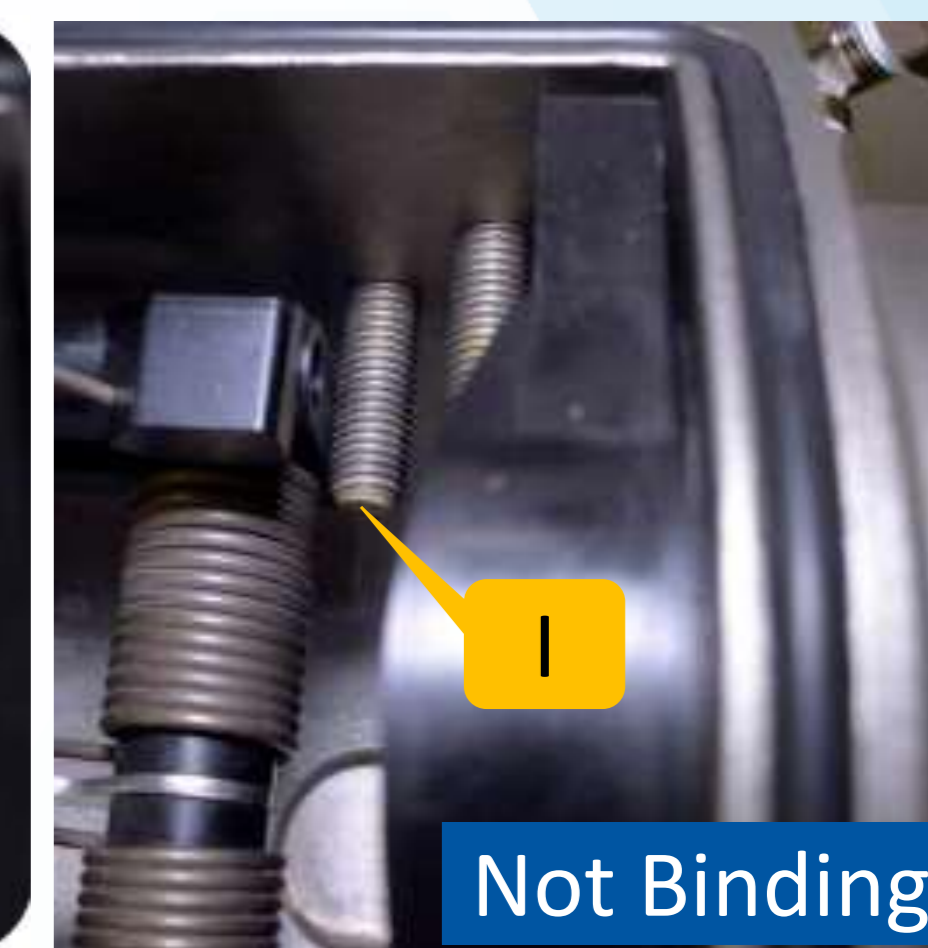
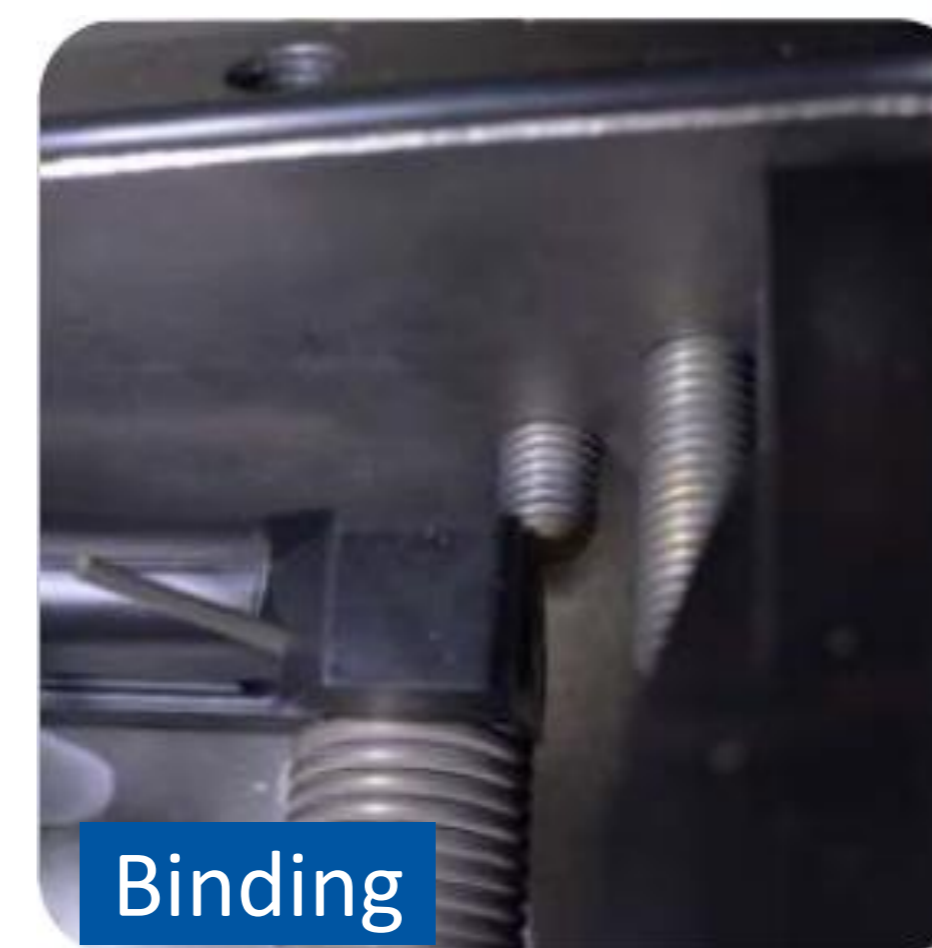
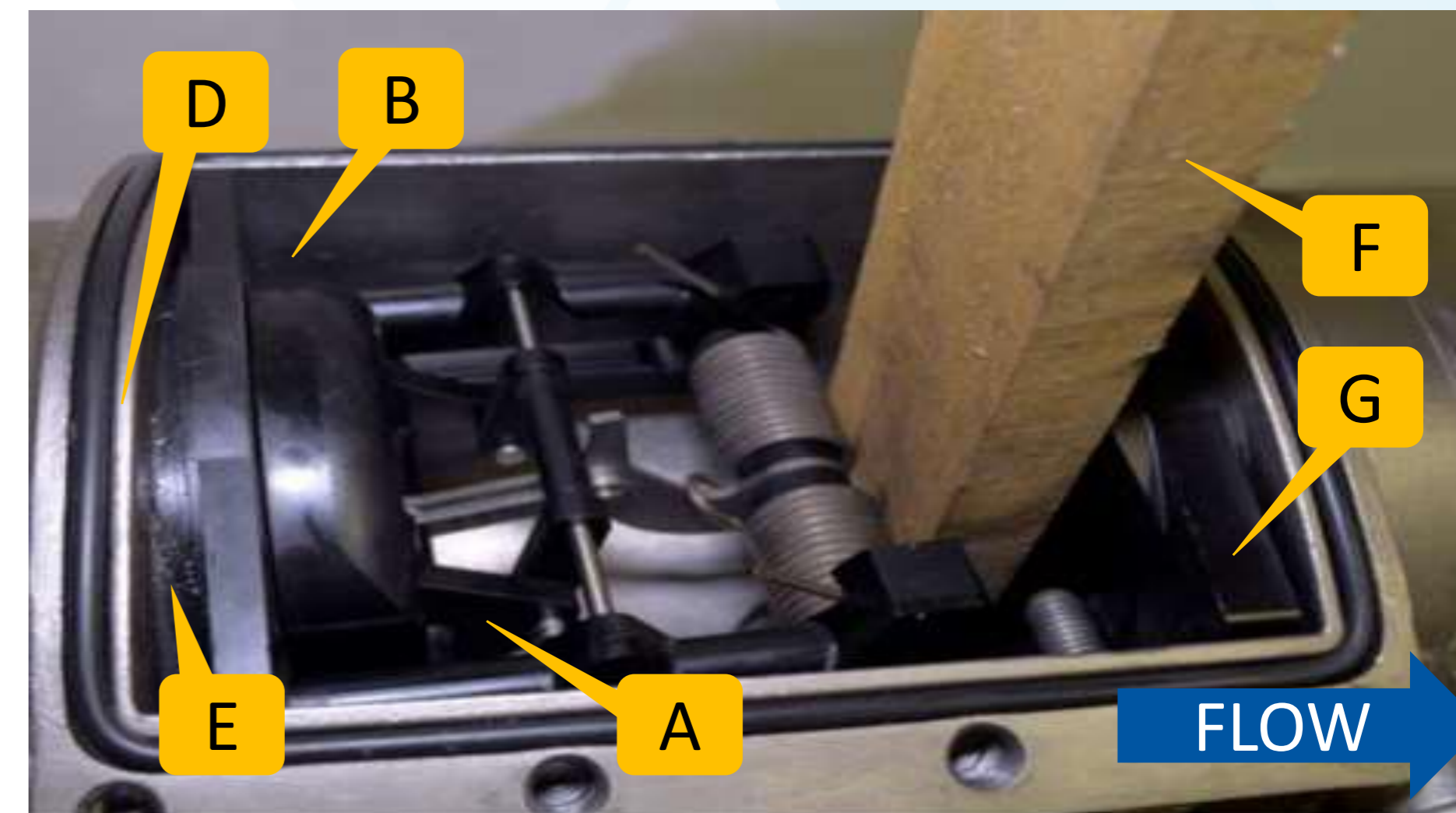

## Installing Access Port Cover

1. It is best to never remove the Access Port O-ring (A). Should the Access Port O-ring (A) become dislodged, simply insert it back into Access Port Groove (B).
2. Slide the Access Port Cover (C) into place being certain that Access Port O-ring (A) does not become dislodged during the process.
3. Insert Cover Bolts (D) and Tapered Washers (E) into Tapered Cover Holes (F). Tapered Washers (E) must be properly installed or the Access Port Cover (C) will not seal under pressure.
4. Use Ratchet Wrench (G) to sequentially tighten all Cover Bolts (D) alternating from one side of the valve to the other.

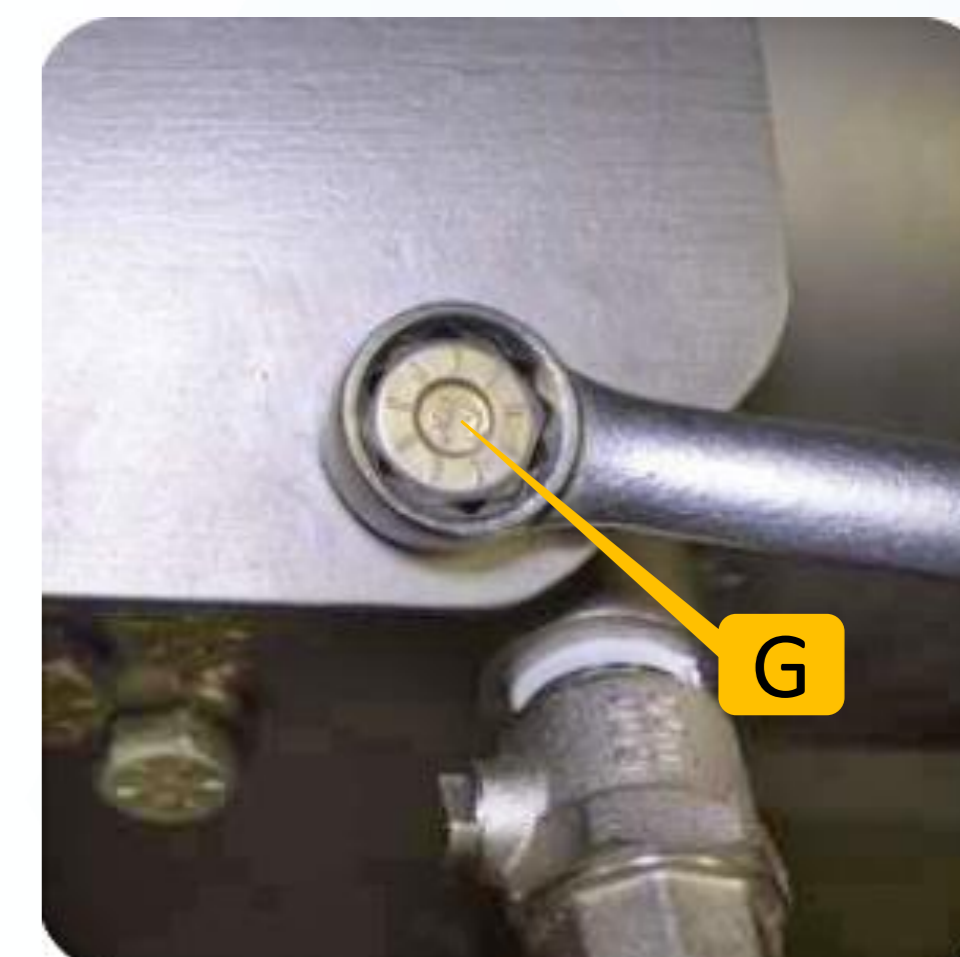
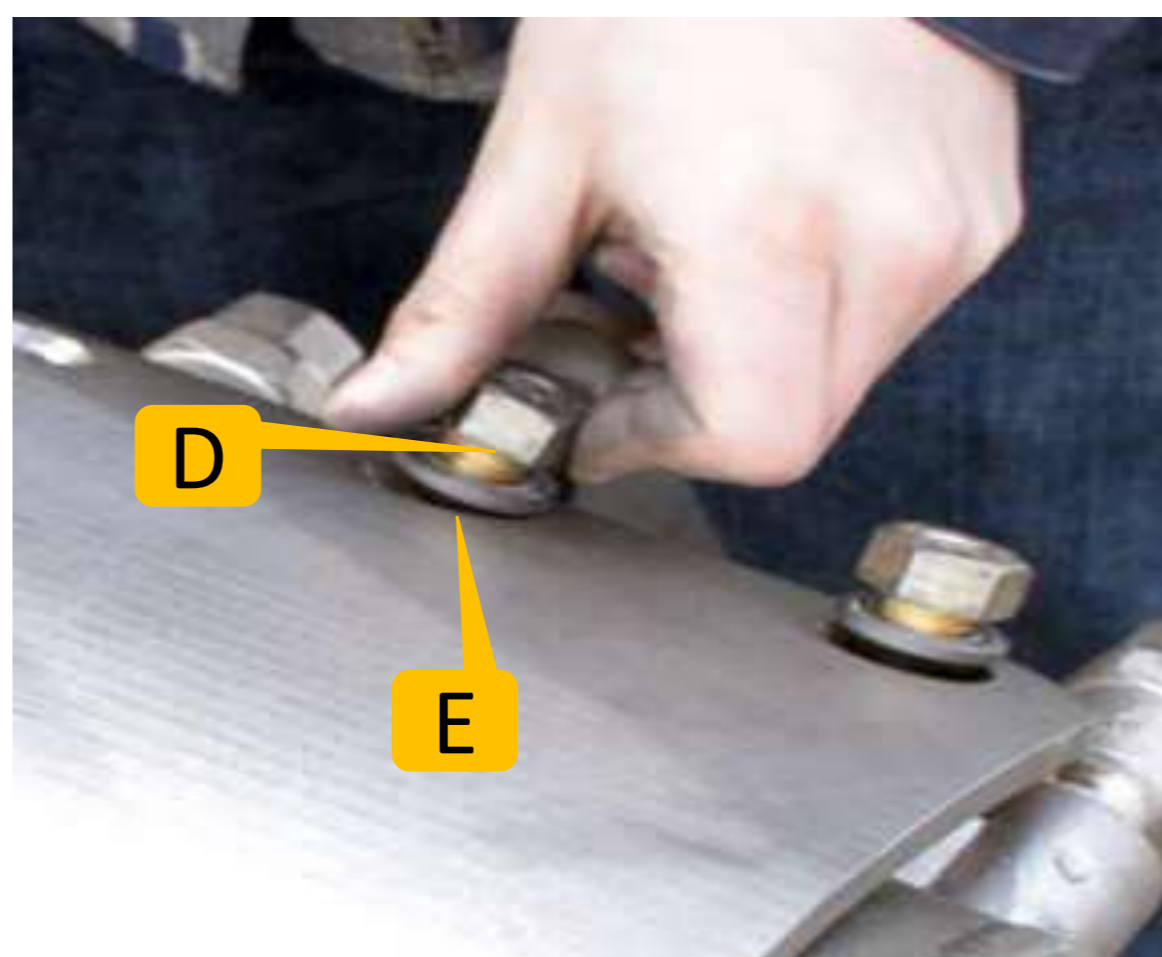
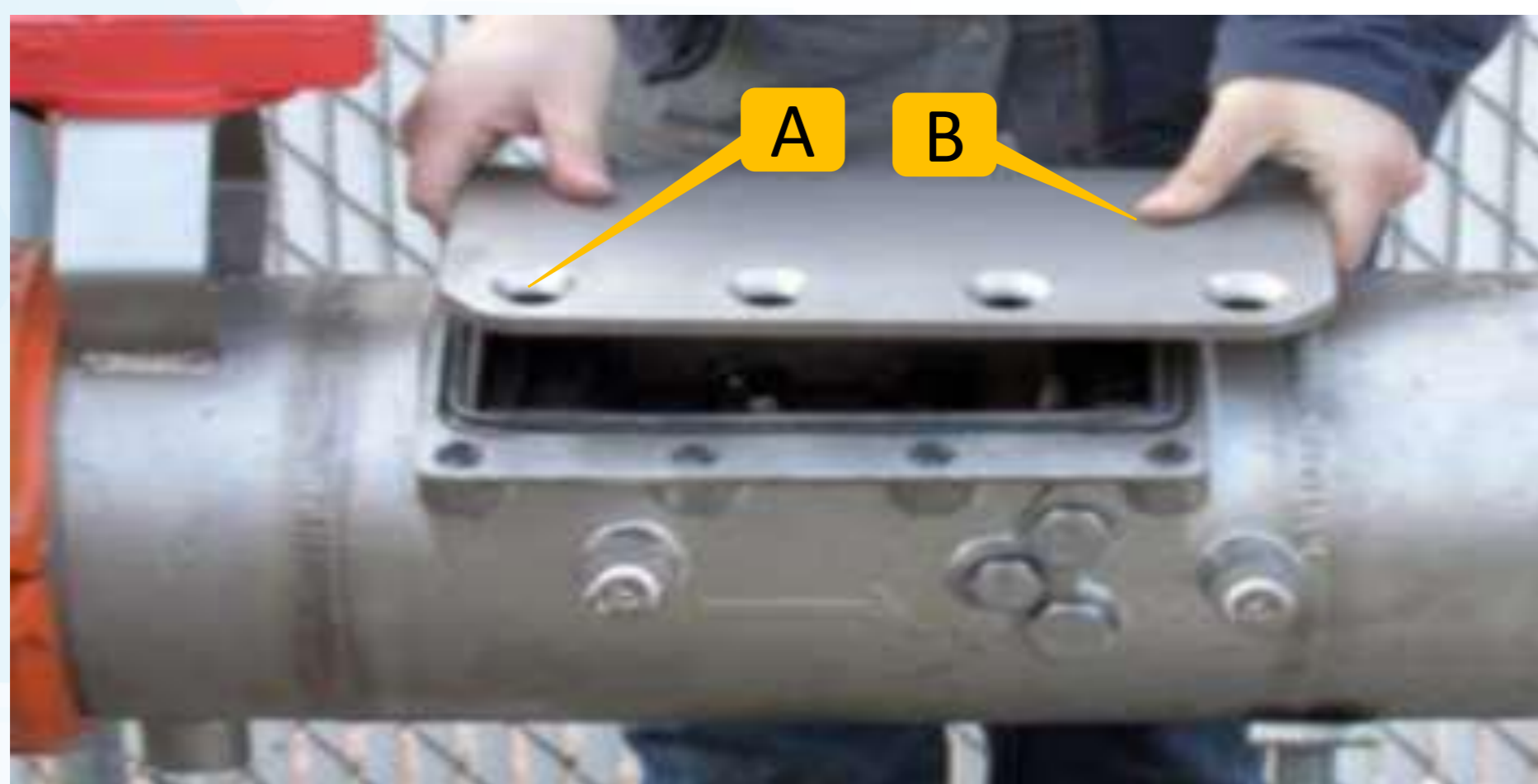
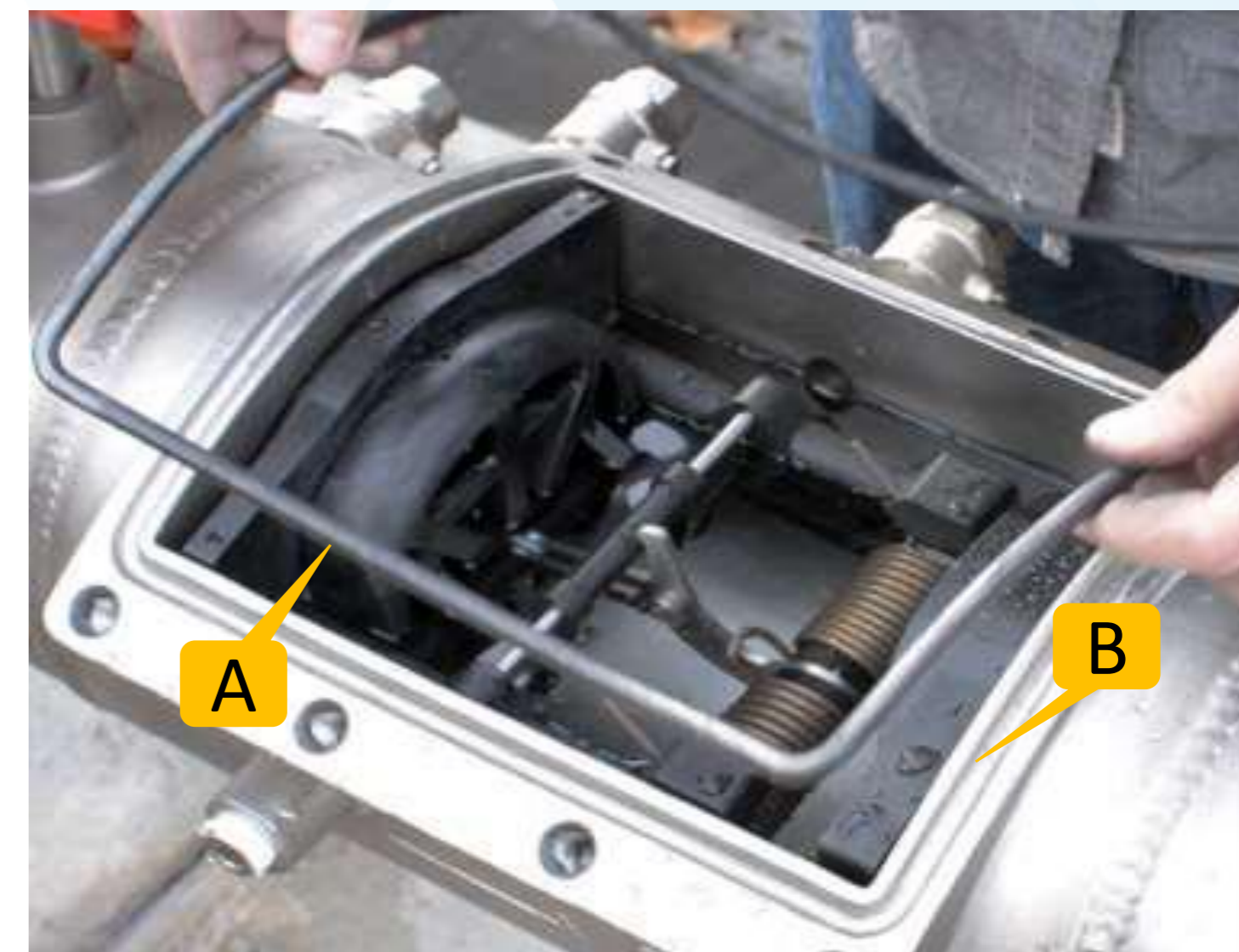

## Close Test Cocks and Double Check all Closing/Sealing Mechanisms

1. Slightly open shut off valve #1 and using the BEECO Test Cock Wrench or a small adjustable wrench slightly close Main Test Cocks Number 2, 3 and 4 (A) to allow excess air to be released before closing the test cocks completely.
2. Double check to be certain that all Cover Bolts are Tightened (B)

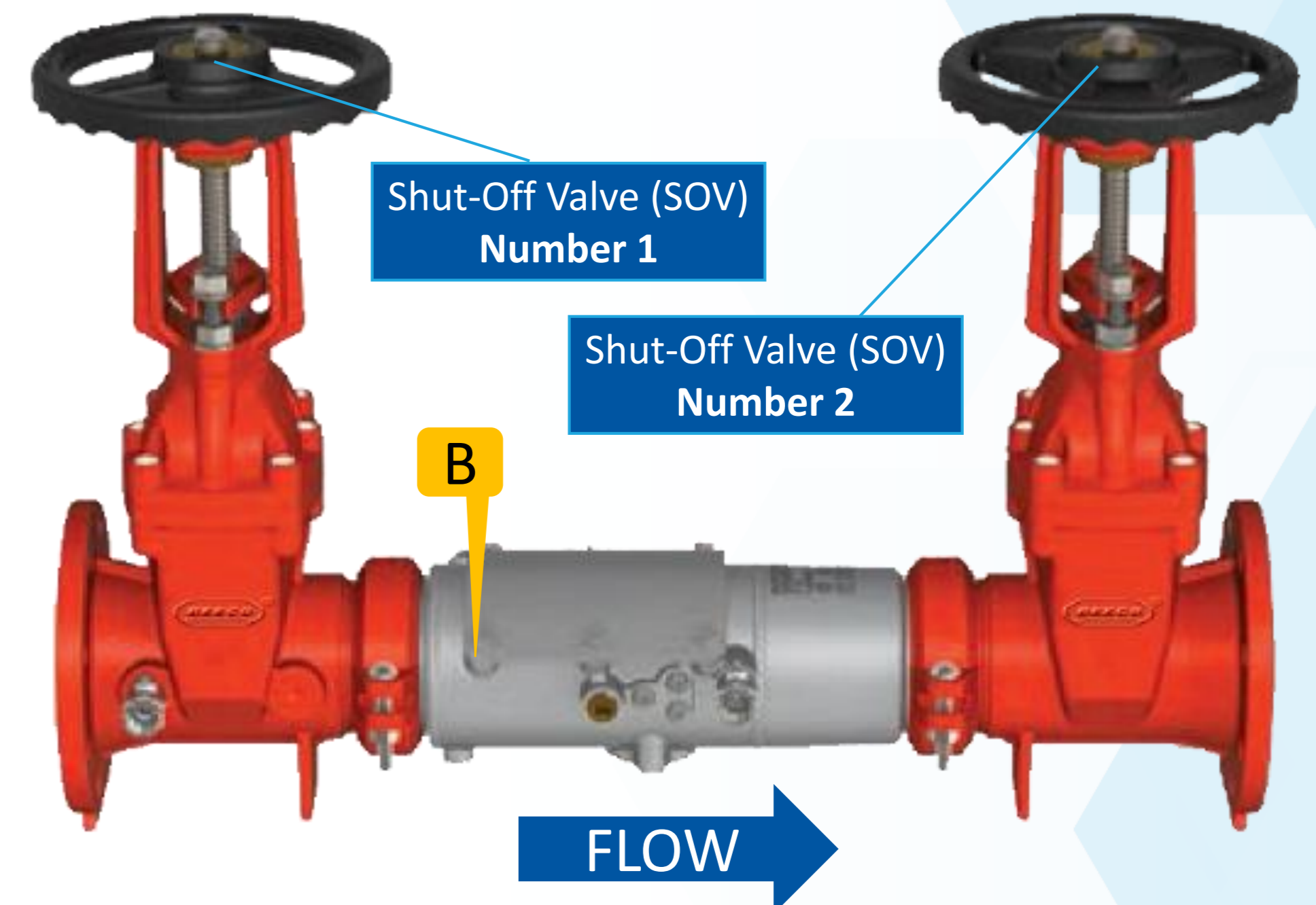
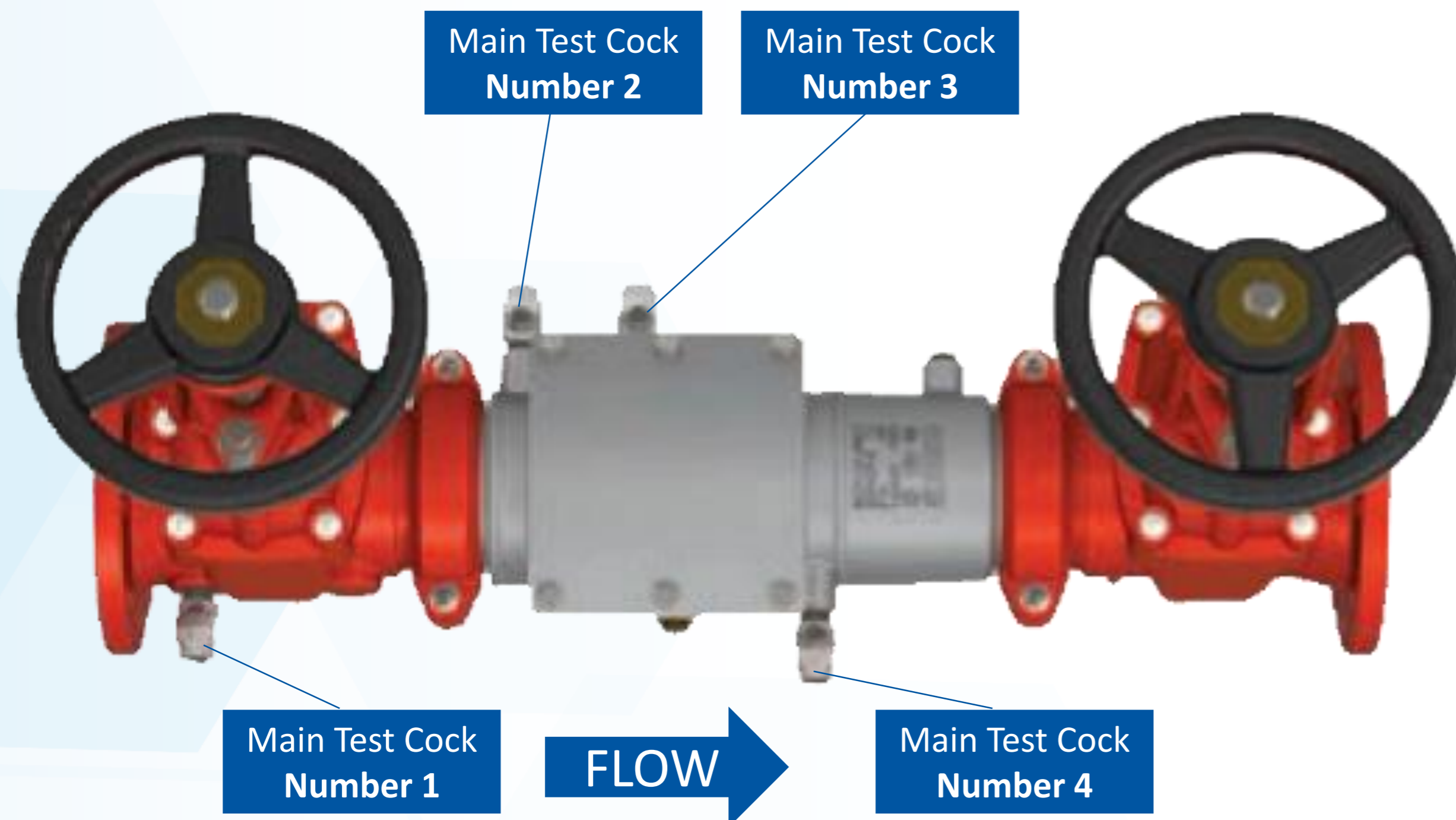
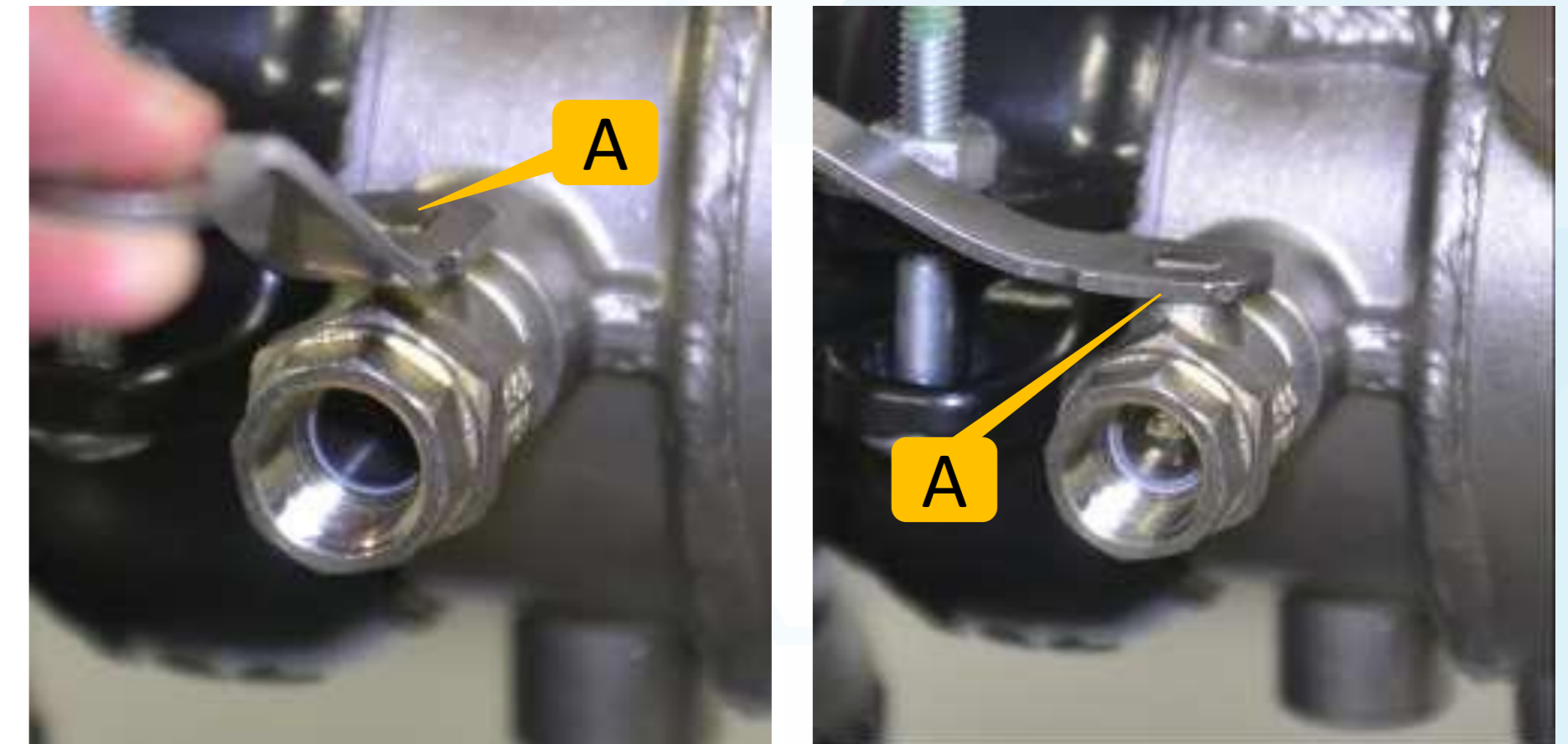



## Open Shut-Off Valves to make Backflow Preventer

### Functional

1. Slowly rotate the Number 1 Shut-Off Valve Operation Handle (A) counter clockwise to the open position.  
(Shut-Off Valve is open when yellow/orange position indicator flags are parallel to the mainline water flow)
2. As the valve fills with water air will be pushed through the Test Cocks. Once a steady flow of water is released from the Test Cocks close in order (2, 3 Then 4. Test Cock is closed when wrench flats on stem are perpendicular to water flow through Test Cock).
3. Slowly rotate the Number 2 Shut-Off Valve Operation Handle (B) counter clockwise to the open position.

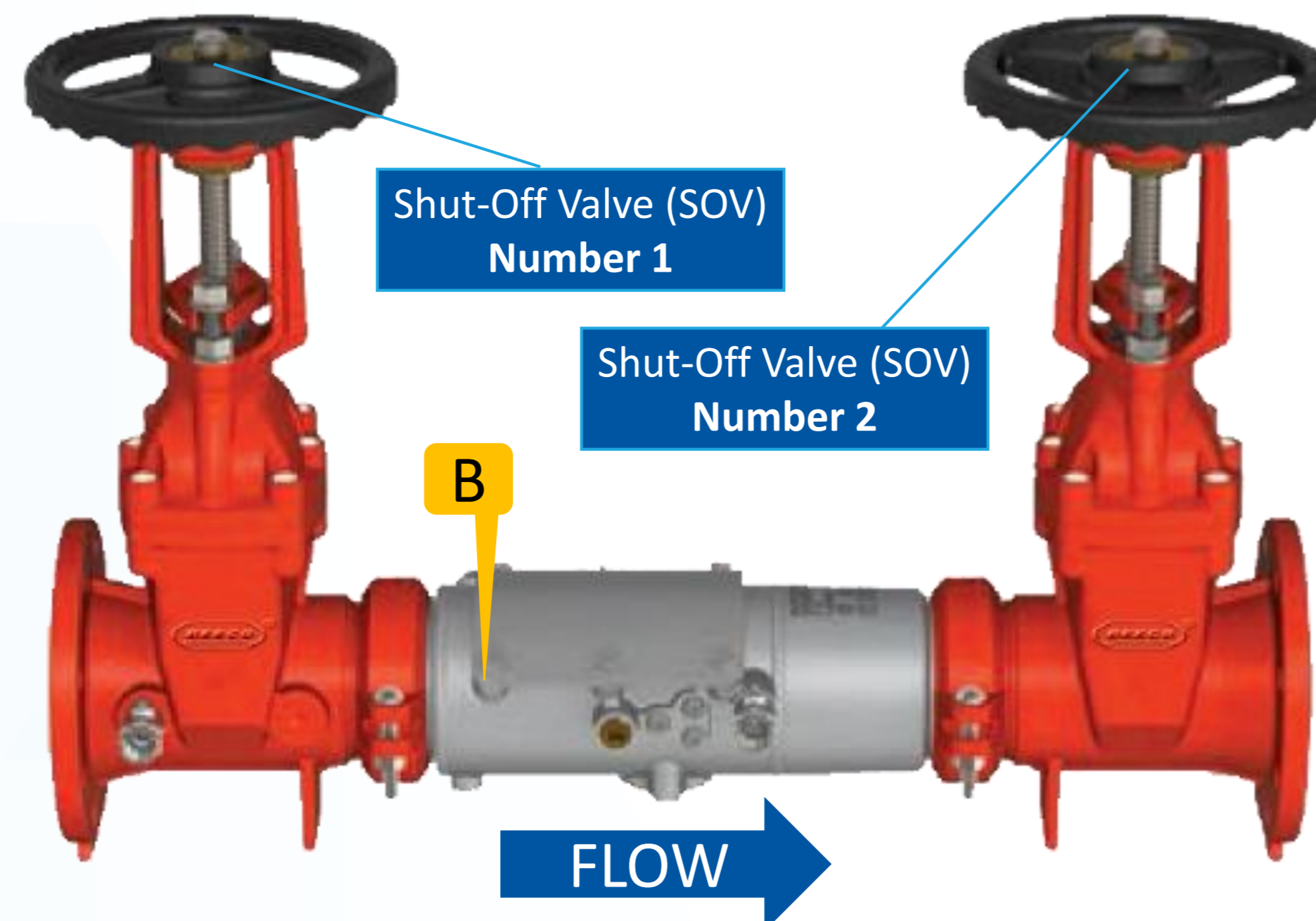

# THANK YOU



Distributed by:  **MIFAB**®